

Review

Corresponding author:*Leo R. Quinlan, PhD**

Physiology

School of Medicine

NUI Galway, University Road

Galway, Ireland

Tel. +353-91-493710

E-mail: leo.quinlan@nuigalway.ie**Volume 1 : Issue 5****Article Ref. #: 1000SEMOJ1121****Article History:****Received:** July 2nd 2015**Accepted:** September 28th, 2015**Published:** September 28th, 2015**Citation:**

Mooney R, Corley G, Godfrey A, Osborough C, Quinlan LR, ÓLaighin G. Application of video-based methods for competitive swimming analysis: a systematic review. *Sport Exerc Med Open J*. 2015; 1(5): 133-150. doi: [10.17140/SEMOJ-1-121](https://doi.org/10.17140/SEMOJ-1-121)

Application of Video-Based Methods for Competitive Swimming Analysis: A Systematic Review

Robert Mooney^{1,2}, Gavin Corley^{1,2}, Alan Godfrey³, Conor Osborough⁴, Leo R. Quinlan^{5,6*} and Gearóid ÓLaighin^{1,2,6}¹*Electrical and Electronic Engineering, School of Engineering and Informatics, NUI Galway, University Road, Galway, Ireland*²*Bioelectronics Research Cluster, National Centre for Biomedical Engineering Science, NUI Galway, University Road, Galway, Ireland*³*Institute for Neuroscience, Newcastle University, Newcastle upon Tyne, United Kingdom*⁴*Department of Exercise and Sports Science, Manchester Metropolitan University, Crewe, UK*⁵*Physiology, School of Medicine, NUI Galway, University Road, Galway, Ireland*⁶*CÚRAM (Centre for Research in Medical Devices), NUI Galway, University Road, Galway, Ireland***ABSTRACT**

This paper explores the application of video-based methods for the analysis of competitive swimming performance. A systematic search of the existing literature was conducted using the following keywords: *swim**, *performance*, *analysis*, *quantitative*, *qualitative*, *camera*, *video* on studies published in the last five years, in the electronic databases ISI Web of Knowledge, PubMed, Science Direct, Scopus and SPORT discuss. Of the 384 number of records initially identified, 30 articles were fully reviewed and their outcome measures were analysed and categorised according to (i) the processes involved, (ii) the application of video for technical analysis of swimming performance and (iii) emerging advances in video technology. Results showed that video is one of the most common methods used to gather data for analysing performance in swimming. The process of using video in aquatic settings is complex, with little consensus amongst coaches regarding a best-practice approach, potentially hindering usage and effectiveness. Different methodologies were assessed and recommendations for coaches, sport scientists and clinicians are provided. Video is an extremely versatile tool. In addition to providing a visual record, it can be used for qualitative and quantitative analysis and is used in both training and competition settings. Cameras can be positioned to gather images both above and below the water. Ongoing advances in automation of video processing techniques and the integration of video with other analysis tools suggest that video analysis will continue to remain central to the preparation of elite swimmers.

KEYWORDS: Swimming; Video analysis; Coaching; Biomechanics; Qualitative; Quantitative.**ABBREVIATIONS:** PRISMA: Preferred Reporting Items for Systematic Reviews and Meta-analyses; MEMS: Micro-Electro-Mechanical Systems.**INTRODUCTION**

Elite sporting success is achieved through gradual improvements over an extended period of time, to ensure that the athlete has achieved a sufficient level of physical conditioning and technical expertise. Central to this process is a detailed training plan which is prepared by the coach and monitored using a variety of means, with video-based analysis arguably the most common methodology employed in elite sport. Unsurprisingly therefore, many reviews have been published on the various applications of video in sport, including technical recommenda-

Copyright:

© 2015 Quinlan LR. This is an open access article distributed under the Creative Commons Attribution License, which permits unrestricted use, distribution, and reproduction in any medium, provided the original work is properly cited.

tions¹ applications in coaching and feedback;²⁻⁴ human motion tracking and analysis;⁵⁻⁷ and technological advances.⁸

There are various methods by which video analysis is applied in different sports.^{3,4} A recent review of the development of video technology in coaching settings examined key questions about why and how sports coaches apply video-based methods.⁴ That author proposed that the main reason why video is used is to provide an objective record of performance, providing evidence that can be reviewed and analysed. To further understand the application of video in particular situations, reviews have been carried out for specific sports such as soccer;⁹ tennis¹⁰ and golf.¹¹ Video analysis has been used for various purposes, including tactical; technical; physical and mental applications in different sports.¹²

The use of video in competitive swimming is widespread, with close to three quarters of coaches based in the United States using video on a monthly basis.¹³ This is not unexpected as underwater video cameras can be positioned in ways that can record what the coach cannot see from the pool deck, thus providing him/her with additional insight into the athletes' performances. This is essential to ensure that swimmers develop a good technique, not just for performance gains but also to reduce the risk of injury.¹⁴ Previous research has shown that video is used by swimming coaches mainly as a qualitative tool.¹³ This is intuitive as the qualitative process is more straightforward to implement in applied settings compared with quantitative practices. However, Lees¹⁵ has argued that there is a lack of information regarding the specific qualitative methods used in elite sport and also a shortage of evidence of how successful this approach may be. In a swimming context, this appears to be valid, with a dearth of published research papers outlining the application of qualitative video analysis and providing evidence of the effectiveness of the approach.

Video is also widely utilised for quantitative purposes in swimming for various applications including assessing technique, for race analysis; as a teaching tool; or as part of a medical screening process. Additionally, video is the primary means by which data for swimming research are collected and has allowed researchers to greatly advance our understanding of the mechanics governing each of the four competitive swimming strokes.¹⁶⁻¹⁹ Callaway, Cobb, and Jones²⁰ reviewed how our understanding of swimming mechanics has developed through video analysis, focusing on research breakthroughs and making comparisons with newer sensor based technologies. Others have provided an extensive examination of the technical aspects of underwater videography, with an emphasis on calibration and reconstruction procedures.²¹⁻²³

No review has been published specifically assessing the processes by which video is captured in applied swimming settings. This may result in uncertainty amongst coaches and practitioners regarding the most appropriate methodologies to be

adopted and the value of video in swimming. Additionally, it is the view of the authors that such a review could serve to provide recommendations for coaches, sports scientists and clinicians, given the challenges of working in an aquatic environment. This may lead to increased consistency in approaches to video analysis in competitive swimming to ensure the efficiency and effectiveness of coaching practices is maximized. The aim of this paper is to systematically review the applications of video-based systems for the analysis of competitive swimming. The review will focus on the processes involved in video analysis in competitive swimming; the interpretation and feedback of data for technical analysis; and will outline future developments currently emerging in the literature.

METHODS

A systematic review of the available literature on the application of video-based methods for the analysis of competitive swimming performance was conducted according to PRISMA (Preferred Reporting Items for Systematic Reviews and Meta-analyses) guidelines in an attempt to address the following review questions: (1) what are the processes involved in obtaining video-based data for swimming analysis, (2) how can the video footage be interpreted and presented for technical analysis of swimming performance and (3) what are the emerging advances in video-based technology for competitive swimming analysis. The electronic databases ISI Web of Knowledge, PubMed, Science Direct, Scopus and SPORTDiscus were searched for relevant publications over a five year period to the end of June 2015, using the following keyword search string: (*swim OR swimming OR swimmer*) AND (*performance OR analysis OR quantitative OR qualitative*) AND (*camera OR video*). The inclusion criteria for these articles were: (1) that they provided sufficient detail regarding the equipment specifications and experimental setup; (2) that they include relevant data regarding the application of video based methods for the analysis of competitive swimming performance; (3) that they were published in the last five years (1st July 2010-1st July 2015) and (4) that they were written in the English language. Studies were excluded if they: (1) did not involve human competitive swimmers; (2) did not provide sufficient detail to answer at least one of the review questions and (3) were published as part of conference proceedings.

RESULTS

The outcomes of the systematic search strategy process is summarised in Figure 1. The initial search identified 384 records. Reference manager software (EndNote X5, Thomson Reuters, Philadelphia, PA, USA) was used to collate results. Duplicates were removed and a screening process of both the title and abstract of the remaining records was subsequently conducted. The full-text of the remaining records was then assessed for relevance to the review. Following this procedure, 30 articles remained for the systematic review (Table 1).

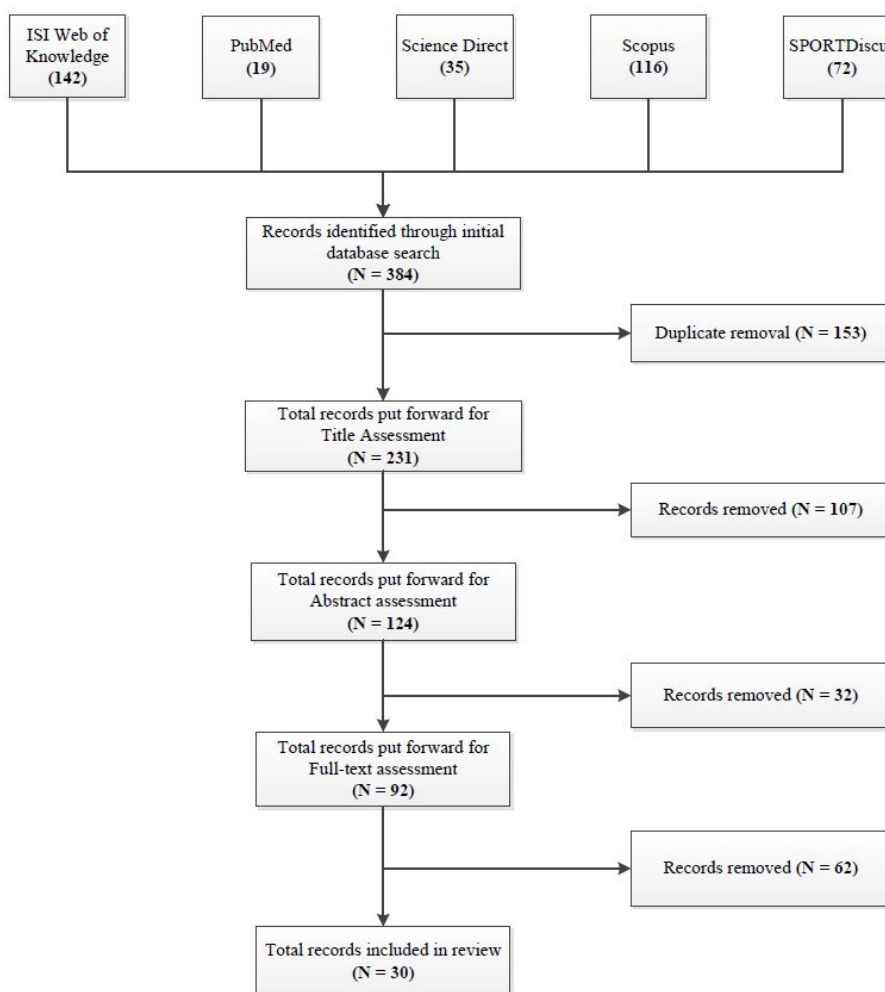

Figure 1: Flowchart of the systematic literature search.

Reference	Purpose of Study	Exp. Design	No. of cameras	Camera config.	Plane(s) of movement	Enclosures (for UW camera)	Frame rate	No. of anatomical landmarks	Camera positioning	Variables measured using video
24	Quantify shoulder kinematics in backstroke and compare between advanced and intermediate level swimmers	2D	1AW	Static	Frontal	Viewing window	50 Hz	4	2.3 m above water FoV: 2 x 2 m	Shoulder entry angles
25	Analysis of freestyle kinematics using a markerless system	3D	6UW	Static	Sagittal, frontal	Water-proof housing	Unrep.	0	0.0-1.65 m depth	Shoulder, elbow & wrist joint angles
26	Examination of the effect of breathing patterns on freestyle swimming kinematics	3D	4UW 2AW	Static	Sagittal	Water-proof housing	50 Hz	19	UW: 8 m from swimmer, 0.5 - 1.8 m depth, 75-110° optical axis AW: 12 m from swimmer, 100° optical axis FoV: 6.5 m per camera	Shoulder & hip roll
27	Effect of fatigue on kinematics of butterfly swimming	2D	1UW 1AW	Static	Sagittal	Water-proof housing	50 Hz	13	UW: 1.6 m depth AW: 0.9 m above water 2.1 x 3.0 calibration space 9 m from plane of movement	Velocity, stroke length, stroke rate, intra-cyclic velocity variation, stroke duration, hand & foot displacement

Reference	Purpose of Study	Exp. Design	No. of cameras	Camera config.	Plane(s) of movement	Enclosures (for UW camera)	Frame rate	No. of anatomical landmarks	Camera positioning	Variables measured using video
28	Examination of the variability on arm coordination patterns in freestyle	3D	4UW 2AW	Static	Sagittal, frontal	Unrep.	50 Hz	21	UW: 75-110 ° optical axis AW: approx. 100 ° optical axis	Velocity, stroke length, stroke rate
29	Analyse the effect of increased energy cost on kinematics of freestyle swimming	2D	1UW 1AW	Static	Sagittal	Water-proof housing	50 Hz	0	UW: 0.5 m depth FoV: 5 m	Stroke rate, stroke length, velocity, arm coordination, energy cost
30	Analysis of kinematic differences in freestyle performance between sprint and distance swimmers	3D	4UW 2AW	Static	Sagittal	Water-proof housing	50 Hz	19	UW: 8 m from swimmer, 0.5-1.5 m depth, 75-110 ° optical axis AW: 12 m from swimmer, 100 ° optical axis FoV: 6.5 m per camera	Average velocity, stroke length, stroke rate, stroke duration, arm & foot displacement, shoulder, elbow & hip joint angles
31	Qualitative analysis of breaststroke technique	2D	1UW	Static	Sagittal	Viewing window	25 Hz	0	Unrep.	Water displacement due to kicking patterns
32	Kinematic and kinetic analysis of tumble turn performance	3D	5UW	Static	Sagittal, transverse	Water-proof housing	50Hz	17	0.7-2.0 m depth 45-60° optical axis	Temporal, kinematic & kinetic parameters related to turn performance (integrated with force platform)
33	Effect of starting block setup on the kinematics of track start performance	2D	1AW	Static	Sagittal	N/A	125 Hz	14	2 m from plane of motion	Block time, velocity (horizontal, vertical, resultant), flight distance, take off angle, rear foot take off time
34	Comparison of different feedback methods on glide performance	2D	1UW 1AW	Static	Sagittal, frontal	Water-proof housing	50 Hz	5	UW: 10 m from swimmer AW: 5 m from swimmer FoV: 9 m	Initial & average velocity, glide factor
35	Investigation of individual variations in limb coordination patterns	2D	2UW 1AW	Static, trolley	Sagittal, frontal	Water-proofed camera	50 Hz	0	UW: 0.4 m depth FoV: 10 m (side view)	Average speed, stroke length, stroke rate, IdC
36	Kinematical analysis of arm motion in freestyle using CAST technique	3D	6UW	Static	Sagittal, frontal	Water-proof housing	Unrep.	31	0.0-1.65 m depth	Shoulder & elbow joint angles
37	Comparison of different backstroke starting techniques	2D	1UW 1AW	Static	Sagittal	Water-proof housing	50 Hz	13	UW: 0.3 m depth AW: 0.3 m above water 2.5 m from head wall of pool 2.1 x 3.0 m ² calibration space	Centre of mass position and velocity, contact time, take off angle, back angle arc, flight distance, start time
38	Effect of resistance on propulsive forces during freestyle sprint swimming	3D	4UW	Static	Sagittal	Periscope	60 Hz	11	3 x 1x 1 m ³ capture volume	Pitch & sweepback angles, hand velocity, propulsive forces
39	Characterization of backstroke swimming kinematics at high intensity	2D	2UW	Static	Sagittal, frontal	Water-proof housing	50 Hz	12	6.3 m ² capture space	Average velocity, stroke rate, stroke length, stroke index, IdC
40	Investigation of correlation between technique with velocity profile in breaststroke swimming	2D	1UW 1AW	Trolley	Sagittal	Water-proofed camera	50 Hz	0	UW: 1.0 m depth 5 m from plane of motion	Stroke phase analysis (arms & legs), stroke rate, stroke length, IdC, speed

Reference	Purpose of Study	Exp. Design	No. of cameras	Camera config.	Plane(s) of movement	Enclosures (for UW camera)	Frame rate	No. of anatomical landmarks	Camera positioning	Variables measured using video
41	Analysis of the kinematics of backstroke turns	2D	4AW	Static	Sagittal	N/A	25 Hz	0	All cameras positioned 7 m above and 7 m away from pool 2 cameras fixed at ends of pool, perpendicular to plane of motion, 2 cameras fixed with optical axes crossed (one from 0-15 m and the other from 10-25 m)	Turn time (7.5m round trip), distance in, UW distance, velocity, normalized velocity, stroke velocity
42	Examination of dolphin kicking performance	2D	1UW	Static	Sagittal	Water-proofed camera	30 Hz	12	0.5 m depth, 7.5 m from push-off wall, 4 m from swimmers plane of motion	Kick symmetry, displacement, amplitude & frequency. Horizontal centre of mass velocity, relative angles for ankle, knee, hip, shoulder, elbow, wrist, upper waist, lower waist & chest.
43	Examination of the pitching effects of buoyancy using a markerless system	2D	2UW 1AW	Trolley, towing cable	Sagittal, transverse	Unrep.	50 Hz	0	Unrep.	Centre of mass & centre of buoyancy positions, buoyancy torques, moment of inertia
44	Effect of breathing patterns on freestyle swimming kinematics	2D	1AW	Static	Sagittal	N?A	50 Hz	2	2.35 m above water Approx. 11.7 m from swimmer FoV: 7.5 m	Stroke rate, stroke length, velocity
45	Assess the effect of leg kicking dynamics on freestyle kinematics	3D	4UW	Static	Sagittal	Periscope	60 Hz	6	3 x 1 x 1 m ³ capture volume	Stroke rate, stroke length, velocity, intra-cyclical hip velocity, IdC, pitch & sweepback angles
46	Determine the accuracy of a 3D kinematics system for swimming analysis	3D	8AW	Static	Sagittal, frontal	Viewing window	200 Hz	4	0.55-2.0 m height 1.4-1.9 m from viewing window 0.45-1.8 m between cameras	Sweepback & pitch angles
47	Effect of aerobic training on freestyle kinematics	2D	2UW 1AW	Static & panning	Sagittal, frontal	Water-proof housing	50 Hz	0	UW: panning camera positioned at mid-pool, static camera captured frontal plane AW: profile view of entire swim trial	Stroke rate, stroke length, velocity, IdC, propulsive phase duration
48	Examination of the kinematics of the backstroke start technique	2D	1UW 1AW	Static	Sagittal	Viewing window	60 Hz	14	UW: 1.0m depth AW: 0.2m above water 7.5 m from plane of motion	Hip & knee joint angles, angular velocity, hip & toe displacement, time to 5m
49	Assessing the relationship between coordination and energy cost of freestyle and breaststroke swimming	2D	2UW	Static	Sagittal, frontal	Unrep.	50 Hz	0	FoV: 10 m, between 10 & 20 m mark in 50 m pool	Average velocity, stroke rate, stroke length, IdC, stroke phases, kick rate, arm & leg coordination
50	Analysis of kinematic parameters relevant to starts and turns, comparing national and regional level swimmers	2D	2AW	Static	Sagittal	N/A	25 Hz	0	Cameras positioned 7 m above and 7 m away from pool	Turn distance & velocity, start distance & velocity

Reference	Purpose of Study	Exp. Design	No. of cameras	Camera config.	Plane(s) of movement	Enclosures (for UW camera)	Frame rate	No. of anatomical landmarks	Camera positioning	Variables measured using video
51	Examination of the impact of verbal feedback on technique	2D	1 UW 1 AW	Static	Sagittal	Water-proofed camera	50 Hz	3	Cameras fixed mid-pool FoV: 15 m	Stroke rate, stroke length, velocity
52	Investigation of path linearity in elite free-style swimmers	2D	2 AW	Static	Sagittal	N/A	50 Hz	0	6 m above water 15 m from plane of motion FoV: 40 m	Forward & lateral speed fluctuations
53	Examination of the effect of swim speed on coordination in Paralympic swimmers	2D	2 UW	Trolley	Sagittal	Water-proof housing	50 Hz	4	6.5 m from swimmer (left and right sides), FoV: included whole body of participants, 10 m test window	Arm and leg cycle phases, swim speed, stroke frequency, kick frequency, kick pattern, downbeat time, upbeat time, pull time, recovery time, leg to arm coordination

Table 1: Results of systematic review search summarising studies conducted that apply video-based systems for the analysis of swimming performance. Results are presented in chronological order and include the purpose of the study; experimental and equipment details; the number of anatomical landmarks and the variables that were measured using the video footage. Abbreviations: UW: Underwater; AW: Above Water; FoV: Field of View; Unrep: Unreported; IdC: Index of coordination.

DISCUSSION

Process of Video Capture

It has been found that technical examination of a swimmer in an applied setting can be undertaken using many different types of video setup and using various analysis methods (Table 1). For example, quantitative or semi-quantitative techniques involve an objective, deductive means of examining components of a performance using specialized instrumentation. Alternatively, a qualitative approach is more inductive in design and analysis is descriptive and subjective in nature.⁵⁴ Qualitative analysis can be carried out to assess the quality of the performance or technique but is also important as a method of identifying the key variables that need to be measured by quantitative means at a later stage.¹ Figure 2 provides an overview of the video analysis process. Three stages are involved: (i) camera selection and setup (ii) video capture and (iii) data processing and analysis. Following these three stages, a coach will interpret the results, provide feedback to the swimmer and decide on appropriate intervention strategies.

Camera Selection and Setup

Equipment specifications: Swimming presents unique challenges to the application of video that warrant consideration. Important issues to consider include light refraction and the effect of water turbulence such as bubbles and splash that are generated by a swimmers movements.^{20,22} Refraction can result in the distortion of an image when light passes from a fast medium (air) to a slow medium (water). An additional concern for underwater recording is water clarity and its effect on image quality. For example, a swimming pool that is excessively aerated will result in high levels of bubbles around the swimmer, making identification of anatomical landmarks on the swimmer difficult (Figure 3).



Figure 3: The motion of a swimmer in the water can cause turbulence resulting in bubbles that make identification of landmarks difficult. Rapidly moving body segments can also result in a blurred image.

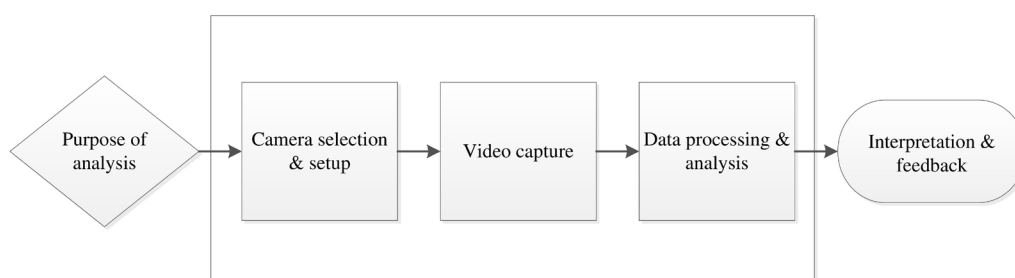

Figure 2: The process of video capture for swimming analysis involves three stages: (i) camera selection and setup; (ii) video capture and (iii) data processing and analysis. This may be conducted in either training or competition settings.

There is a vast array of video cameras to choose from, with both under-water and above-water cameras available from all the major camera manufacturers. Studies that utilise only above-water cameras tend to be analyses based on competition footage.^{41,50,52} However, for a thorough technical examination of swimming using video it is imperative for the swim coach to have an underwater view to fully assess a swimmer's movements. Specialist underwater equipment is available through dedicated manufacturers. Examples include SwimPro, Swim-Right and Qualisys Oqus (Table 2). Some key parameters to consider when choosing a camera include the frame rate and shutter speed. Frame rate refers to the number of individual frames that comprise each second of video, also known as FPS (frames per second). Shutter speed refers to the amount of time that each individual frame is exposed for. It is generally advised that the denominator of your shutter speed should be at least double the number of FPS that you are recording. Consequently, a frame rate of between 25-50 Hz and a shutter speed of between 1/350-1/750 s are recommended for swimming applications to maximise image quality.¹ These frame rates are reflected in the extant literature although some examples of higher values such as 125 Hz and 200 Hz can be found.^{33,46}

Camera System	Shutter Speed (s)	Frames per second (fps)	No. of Cameras	Resolution (Mpixel)	Min Illumination (Lux)
SwimRight Shark Eye Coach	1/50-1/10,000	25-30	1	0.3	1.0
SwimPro IQ Recorder	1/50-1/60,000		1-4	0.6	0.01
GoPro Hero3	1/1-1/8,192	12-240	1	0.4-12.0	1.4
Qualisys Oqus	N/A	180-10,000	1-24	0.3-12.0	0.0

Table 2: Comparison of technical specifications for various underwater cameras systems used in competitive swimming environments, highlighting that no common configuration has been established.

Various solutions have been developed to record underwater motion, including placing the camera in a waterproof

housing;^{25,47,53} using an underwater viewing window^{24,31,46} or alternatively a periscope system^{38,45} (Figure 4). Although periscope systems were frequently used in the past,⁵⁵⁻⁵⁸ waterproof camera housings would appear to now be the most popular choice and offer flexibility in positioning but have short camera to interface distances (the distance between the camera lens and the glass of the waterproof housing) which can result in reconstruction errors (Figure 5).²² Underwater viewing windows allow for increased camera to interface distances but video capture will be limited by access to a swimming pool or flume with built in windows included and may also result in issues with refraction. Inverse periscopes allow for camera's to be positioned above the water to record activity both above and under the water. The advantage of a periscope system is that it allows for a longer camera to interface distance compared to waterproofed camera housings. However, the mirrors used in periscope systems must be of a very high quality to ensure good image quality and consequently periscope systems can be expensive compared with the alternative approaches.²²

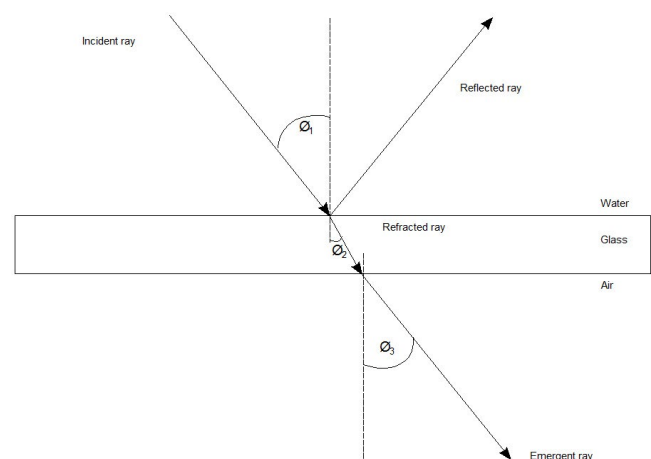
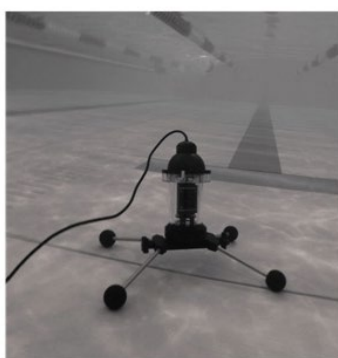
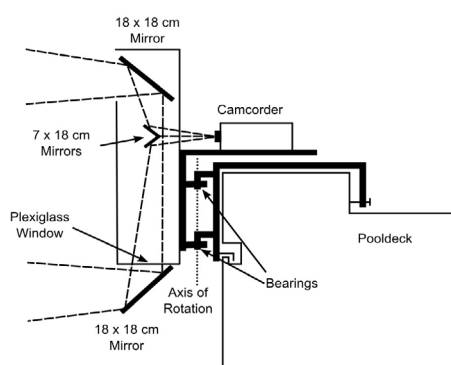

Figure 5: When using a waterproof housing, the distance between the camera lens and the glass of the housing is important as refraction at both the water-glass interface and glass-air interface will cause deformation of the image. The thickness of the glass will also affect the degree of refraction experienced.



(a)



(b)

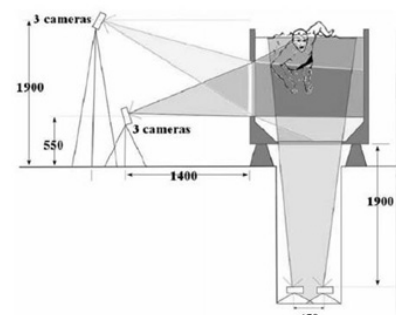

(c)

Figure 4: To capture the underwater movements of the swimmer different options are available for the positioning of cameras including (a) using a waterproof housings such as the Shark Eye system; (b) a periscope system or (c) placing cameras outside the water and tracking the swimmers as they pass underwater viewing windows. Redrawn from Yanai et al. (1996)⁵⁸ (Figure 4B) and Reproduced from Monnet et al. (2014)⁴⁶ (Figure 4C), with permission.

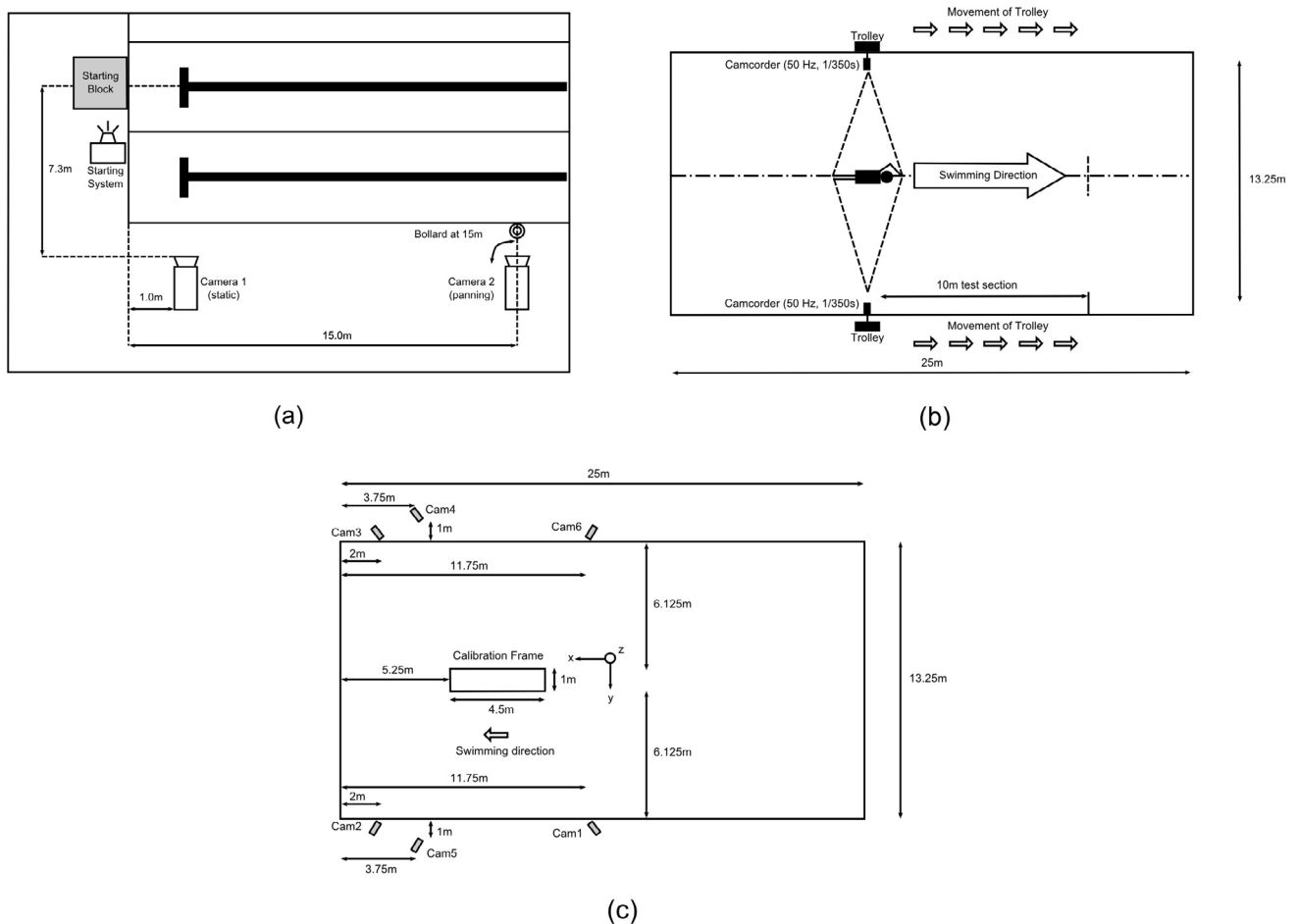

Figure 6: Representative examples of different video setups and configurations for various quantitative analyses. (a) Two above water cameras, one static and one panning, for kinematic and temporal analysis of dive starting technique. Images from the static camera were used for digitization of subjects during block and flight phases whilst the panning camera was used to measure temporal measures for the full 15 m start phase. (b) A trolley system with underwater views from both sides of the pool facilitated following the swimmer over 10m to get three full stroke cycles for kinematic analysis. A graduated rope was fixed below the swimmer and within the field of view to facilitate calibration. (c) Multiple above and below water cameras around a calibrated space of known dimensions (4.5 m x 1.5 m x 1.0 m) and control points distributed at regular intervals allows for a 3D analysis of swimming performance. Redrawn from Mooney (2011)⁶⁰ (Figure 6A); Osborough et al. (2015)⁶³ (Figure 6B); Sanders et al. (2006)⁶¹ (Figure 6C), with permission.

Camera Configuration

Using a single camera offers an ease of portability and setup, and can often be used for a rapid performance assessment.⁵⁹ Use of multiple cameras requires a more complex setup and requires images from different cameras to be synchronized. Between one and eight cameras have been used in studies capturing swimming footage, with various combinations of above-water and under-water cameras.^{31,35,46} Cameras can be positioned to capture the swimmer in the sagittal, transverse or frontal planes, or a combination of these, depending on the analysis requirements^{53,60,61} (Figure 6).

Payton¹ recommended that the size of the athlete in view be maximized in order to reduce perspective error. Perspective error results in the size of an object changing with its distance from the lens and overcoming this is critical in measurement applications involving objects with depth or objects moving relative to the lens. This can be achieved through a combination of increasing the distance from the camera to the performer and choosing an appropriate zoom level. Whilst this is seldom an issue for above water cameras, when recording underwater this

can present a challenge as it can often require several lanes of the pool to be left empty to avoid other swimmers from blocking the view. Moreover, underwater lenses have a fixed focal length (the distance between the centre of the lens and its focus). And do not allow for adjustment in zoom or shutter speeds so it is necessary to increase the distance of the camera position in relation to the swimmer,¹ which may be impractical for many training programmes.

Static cameras are typically used in order to allow for the movement to be assessed relative to an external reference.^{28,34,42} The camera is fixed on a specific field of view and the footage is captured as the swimmer moves past. When using a smaller capture space, issues arise as only a short number of stroke cycles can actually be recorded within the capture space. This may limit the effectiveness of such an approach as it does not allow for variations in swimmers patterns of movement to be fully observed.^{62,63}

Panning cameras introduce additional complexity for accurate measurement⁵⁸ but can be used to capture a swimmers movements through a longer distance, for example over the full

length of an Olympic distance pool.⁵⁹ Alternatively, tracking cameras allow the videographer to manually follow the swimmer throughout the length of the pool using a camera mounted on a trolley or similar device.^{40,43,53} This increases the analysis potential beyond the limited capture volume possible with static cameras.

Calibration procedures: Calibration of a video image for a 2D quantitative analysis requires a scaling object and vertical reference to be recorded before video capture, to facilitate accurate extraction of variables during the digitization stage.¹ Typically, this is achieved using a metre stick. When conducting 3D analysis, a controlled volume is defined according to a calibration frame of known dimensions with control points positioned at known intervals and the calibration frame design must reflect its intended use.

Examples of differently sized calibration frames used in swimming can be found in the literature. Larger frames are capable of capturing the entire swimmer during one or more stroke cycles, with examples as large as 18 m³²¹ and 25.2 m³⁵⁸ previously described. Others have used a calibration frame with dimensions of 4.5 m x 1.0 m x 1.5 m (6.75 m³) which is also suitable for whole body analysis.²⁶ Cappaert, Pease, and Troup⁶⁴ used a 5.6 m³ calibration frame in a whole body swimming investigation. These researchers used digitized footage from four cameras (two below and two above the water) to determine changes in shoulder, hip and elbow angles throughout one stroke cycle, to compare the techniques of elite and sub-elite swimmers.

Conversely, smaller calibration frame sizes have also been utilized.^{38,55-57,65} Payton, et al.⁵⁷ used a frame measuring 1.3 m x 0.93 m x 0.88 m (1.06 m³) and digitized six anatomical landmarks on the shoulder, forearm and hand in order to determine the movements of one arm during a single stroke. Lauder, et al.⁶⁵ previously reported the smallest frame found in a swimming related study, measuring just 0.4 m³ (1.0 m x 0.5 m x 0.8 m). These studies focused on specific aspects of swimmer's arm movements and the relationship of these with propulsion. Smaller frame sizes can result in lower reconstruction errors than larger frames.⁵⁵ These reconstruction error differences be attributed to various factors, including the effects of light refraction; image deformation when recording; the relative size of the reproduced image in relation to the capture volume or issues with the reconstruction algorithms used.^{22,55} A trade off exists in deciding the appropriate calibration frame size and the resultant accuracy of the reproduced image. Additionally, the frame size can be compensated for somewhat by increasing the distance between the camera and the performer.

Video Capture

Preparation of swimmers: There are various factors involved in preparing swimmers for video-based data collection. Some factors are common to both quantitative and qualitative analy-

sis, but quantitative methods will require additional preparation. Swimmers may be required to wear specific clothing (such as different coloured hats or swim-suits to aid identification), have identification markers written on their skin, or some other markers for identifying body landmarks when conducting digitization procedures (Figure 7). Digitization involves the reconstruction of a swimmers body movement by tracking the displacement of markers placed at specific anatomical locations. Up to 31 landmarks have been included in the reviewed literature,³⁶ although the number of specific locations of the markers will depend on the aims of the study. It is important to note that the swimmer cannot typically hear or see the videographer whilst performing trials so it is vital that instructions regarding the protocol are clearly communicated to the swimmer in advance to improve the efficiency and accuracy of data collection.

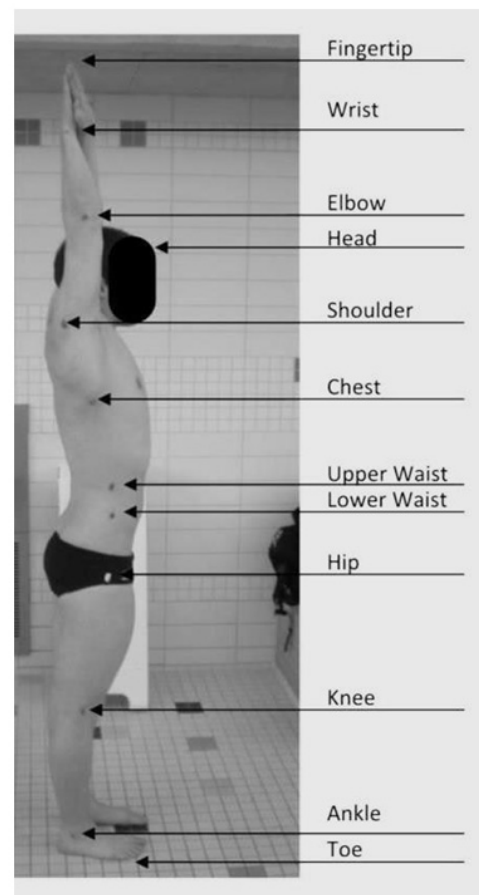

Figure 7: Representation of the anatomical locations of body segments used to facilitate the digitization process for kinematic analysis. The accuracy of the digitization process is dependent on anatomical knowledge when markings are made. Reproduced from Atkison et al. (2013),⁴² with permission.

Video storage and retrieval: Various software packages are available, including Dartfish; Kinovea; Quintic; APAS; Coaches Eye and Simi Motion, for video capture, editing and subsequent analysis. Video requires a large amount of storage space on a computer, with footage of a typical 200 m race lasting 2-3 minutes taking up 250-300 MB. Recordings taken during a training activity are typically longer in duration and require much larger

storage space.

A large volume of recording raises two concerns for the coach. Firstly, a suitable storage solution must be available with sufficient capacity for dealing with multiple recordings over an extended period of time. This may involve a physical hard drive or a cloud based solution. Advances in cloud based computing allow for vast storage and sharing solutions for coaches but this may also involve a lot of time for compressing, uploading and downloading of information when large squads of swimmers are involved. Secondly, a coach must have a system that allows for rapid retrieval of information at a later stage. This may involve manually indexing and tagging data, to attribute information related to a specific swimmer, event or analysis type conducted. Many software packages will include features for this to be carried out or alternatively a coach may develop their own notational system. It is important that coaches and sports scientists working with the same group of swimmers follow a consistent approach for ease of retrieval at a later stage.

Data Processing and Analysis

For a qualitative analysis, it is typically only necessary to edit and store the files for later review. However, processing may involve merging of images from multiple views for thorough assessment. Data processing for quantitative analysis involves additional steps however. Digitization procedures are required to obtain the coordinates of body landmarks from recorded video and can be completed using manual or automatic methods. Manual methods involve an operator having to identify landmarks through visual inspection of each frame of the footage. In order to improve the consistency of the process, the same operator should perform all the digitizing for data to be analysed. Certain limb positions can be difficult to identify due to water turbulence or hidden body segments. Operators should have a sound anatomical knowledge and use markers on the skin only as a guide.

The scaling object or control points must be digitized with a high degree of accuracy as this process is used to generate all other outputs from the system.¹ It is also recommended to assess the level of systematic and random error involved. Errors can arise from various factors including the quality of the video image; the resolution of the digitization software; the size of the calibration volume and the skill of the operator.¹ Error estimation typically involves a both inter-operator and intra-operator reliability testing.⁶⁶⁻⁶⁸ Reconstruction error for 3D analysis of less than 5 mm for each axis is deemed acceptable.^{61,69}

According to swim coaches, a key disadvantage to performing quantitative video analysis methods is the time taken to manually digitize the footage.¹³ Coaches perceive that it takes too long to carry out quantitative analysis and this outweighs any perceived advantage of conducting such work. A recent study reported that it took approximately seven and a half hours to carry out manual digitization of a relatively small amount of

footage, involving ten swimmers performing three dives each.⁷⁰ Magalhaes, et al.⁷¹ also cite another example whereby it took 27 hours to digitize footage of four separate stroke cycles for one swimmer, involving images from six cameras, 19 anatomical landmarks and 1,620 frames in total.⁷²

Automatic digitization offers a clear time-saving advantage over manual methods. However, it is not always possible to complete automatic digitization as markers cannot always be placed on a performer (in a competitive setting for example) and in the water the negative drag effects of markers hinders the swimmers movements significantly. An increase of between 7-10% in passive drag was reported in one study which involved 24 markers, each 19mm in diameter.⁷³ Additionally, underwater and/or outdoor conditions lead to variations in the pixel contrast (the difference in luminance or colour that makes an object or its image representation distinguishable) between the markers and the background and air bubbles in the water can also introduce additional error in automatic procedures, rendering them impractical.¹

Based on the evidence presented in this review, the overall trend in video capture in swimming appears to be towards the use of multiple cameras and that both the underwater and above water images are important to the coach. This is logical as it allows for swimmers movements to be tracked through complete stroke cycles and from multiple planes of motion. Increased availability of low-cost equipment is also facilitating coaches in obtaining these multiple views. Additionally, whilst many 3D analysis setups are found in research practice, there is a much greater emphasis on 2D approaches, especially in applied practice.

INTERPRETATION AND FEEDBACK

Qualitative Technical Assessment

Commonly, a coach will conduct technical analysis using video as an aid to their own observations.^{4,15} This analysis is based on a coach's own knowledge and experience but video allows the coach to prepare, observe, assess and evaluate a swimmer's performance before taking what they consider to be the most appropriate action.^{54,74} A key advantage is that it is low cost and easy to implement with large numbers of athletes. Wilson⁴ suggests that in coaching settings there is more of a focus on qualitative methods as it allows for rapid video feedback to be provided at any stage during a training session. Moreover, qualitative analysis is considered by some to be more intuitive for an athlete, compared with quantitative approaches.⁷⁴ Despite this, limited examples of qualitative swimming research using video can be found.^{31,75,76}

One recent study used a qualitative approach to assess different breaststroke techniques.³¹ By using an underwater camera, researchers were able to use flow visualization techniques to assess the impact of different arm and leg movements (Figure 8).

For example, it was found that supination of the foot at the end of leg extension resulted in increased displacement of the swimmer compared with leg extension without a corresponding foot supination.

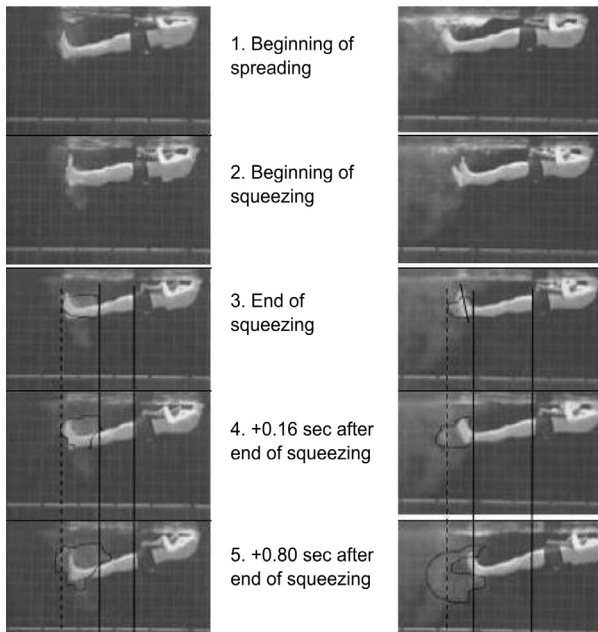

Figure 8: A qualitative assessment of breaststroke kicking action is facilitated through the use of underwater video footage. A fluorescent dye is used to assess the impact of foot supination at the end of leg extension (squeezing). The supinated position (*on right*) results in increased displacement of the swimmer as compared to the non-supinated position (*on left*). Reproduced from Martens & Daly (2012),³¹ with permission.

Another example of the application of video for qualitative assessment is the use of self-modelling. Self-modelling is an observational technique based on preparing a video of an athlete's own performance that has been edited to show a performance level that is greater than what the athlete is currently capable of.⁷⁷ Such an approach has been implemented previously for the learning of swimming skills⁷⁶ and may also have relevance in competitive environments. This may involve taking video footage of a swimmer's four best laps (from a longer race or from different performances) and editing them together with the swimmer's best ever start, turns and finish, to create a video file that the swimmer can then view. This approach has been used in competitive gymnastics and shown to significantly increase performance compared to when no video is provided to the athletes.⁷⁸

This visual feedback on performance is vital for skill acquisition, it raises a swimmer's awareness of their movements in the water and it is suggested that feedback should be provided as quickly as possible during the skill acquisition stage to maximise the learning effect.⁷⁹ Furthermore, it has been believed that the timing and content of feedback information should change as learning and skill development progresses.^{2,8} Video facilitates this augmented feedback approach just as readily.

Video allows for a thorough qualitative evaluation from

any viewing angle to be conducted. As most of a swimmer's movements occur under the water it is difficult for a coach to see what is going on. Therefore, underwater video appears to be just as important for the coach as it is for the athlete. Manipulation of the video image using tools such as slow motion replay, frame-by-frame viewing or split screen comparisons can be used to facilitate both observation and assessment of the performance and highlight issues that could be missed with the naked eye. Moreover, video footage can be used to compare the same swimmer on different occasions to check for changes in technique following a period of training or for the effects of fatigue.

The lack of qualitative swimming research highlighted in this review is of concern as it has been found that coaches most often employ qualitative procedures in their own environments.¹³ However, without a strong evidential basis for its efficacy, it is possible that coaches are not making the best use of the methods, leading to poor practice and potentially inefficient performance gains. Future research should focus on examining the merits of qualitative approaches in applied swimming settings.

Quantitative Technical Assessment

Alternatively, video may be used along with specialist equipment and software to assess swimming technique using quantitative or semi-quantitative means.^{30,35,61,80,81} Whilst qualitative analysis using video has been shown to be an effective method of producing changes in technique compared with verbal coach feedback,¹¹ it has been suggested that quantitative feedback is also important for improving technique rather than using video purely for qualitative analysis.^{34,82} Thow, et al.³⁴ reported significantly greater improvements in both initial and average velocity measurements in elite swimmers during the glide phase following a dive start when swimmers were provided with quantitative feedback to compliment the coach's instructions. Average velocity increased from $1.74 \pm 0.16 \text{ m}\cdot\text{s}^{-1}$ to $1.84 \pm 0.09 \text{ m}\cdot\text{s}^{-1}$ over a five week intervention period. Moreover, whilst the results indicated that a qualitative feedback approach also brought about significant gains in performance, the addition of quantitative data elicited faster improvement gains.³⁴

Video facilitates the quantification of key performance-related parameters, which have been shown to significantly influence overall performance. These quantitative methods can also be applied to injury prevention strategies. Becker and Havriluk⁸³ used video to assess different phases of butterfly swimming technique in order to highlight how changes to technique can reduce the risk of injury by affecting the forces experienced by the swimmers hands as they propel themselves through the water. Furthermore, video has been used to determine stroke asymmetries^{84,85} and has informed musculoskeletal screening procedures to help clinicians and coaches to identify such deficiencies.⁸⁶

The studies included in this review demonstrate that video has been used in a diverse number of ways for providing

analysis in swimming. Whilst some differences can be attributed to the advancement of filming and computer technology, the review does highlight an apparent lack of common approaches for conducting quantitative video analysis in swimming, with different studies using different camera configurations to measure the same variables. What is also apparent is that in-depth quantitative video analysis does not always require a complex experimental setup.

For example, the pitch and sweepback angles of the hand are important factors for generating propulsion.^{45,69} Recent studies have used either two, four or eight cameras positioned either in waterproof housings, behind viewing windows or with a periscope system and have digitized between 4 and 12 anatomical landmarks in order to measure these angles.^{45,50,65,69} Similarly velocity, stroke rate and stroke length have been variously derived using static cameras,²⁹ or cameras with a trolley setup,⁵³ both with and without⁸⁷ digitization procedures. Such diversity in approaches is undoubtedly due to the specific nature of different studies, but may lead to confusion among practitioners as to the best methods to employ in their own environments.

Turns are a vital component of swimming competition and have been shown to be significantly related to overall performance.^{32,88} and as a result have received much research attention.^{32,41,50} Puel, et al. provided a comprehensive three-dimensional analysis of the key parameters related to successful performance of the freestyle tumble turn, using five underwater cameras and an integrated force platform to quantify 51 separate variables. In contrast, Veiga, et al.⁵⁰ recently also assessed turning performance in a group of elite swimmers but used just two above water cameras and measured only turning distance and velocity. Clearly the objectives of these studies differed but it is interesting to consider which study would be more likely to be replicated by a coach in their own environment.

EMERGING ADVANCES IN VIDEO TECHNOLOGY

The criticisms of video appear to be commonly expressed by both researchers and coaches. A central theme of this criticism is the time required to carry out video based procedures.^{13,20,89} This is certainly limiting the frequency of quantitative video analysis performed in applied settings but is likely to also decrease qualitative video practices, given that video editing for multiple swimmers can be very labour intensive in its own right. It is unsurprising therefore that much research attention is currently focused on reducing the time taken to obtain pertinent information using video and on the automation of many of the laborious manual procedures involved.^{2,6,8,90} By way of example, one recently reported automated digitization approach claims to reduce processing time by a factor of ten over manual tracking methods.⁴⁶

Automated Tracking Systems

One automated tracking approach uses an array of

LED's mounted on flexible circuit board that was worn by the swimmer.⁹¹ The system removes the requirement for manual digitization and initial testing suggests comparable accuracy to manually derived variables related to swimming starts and turns. Another automated tracking system recently described is based on the Calibrated Anatomical System Technique (CAST).³⁶ The CAST system, frequently seen in clinical settings, estimates anatomical landmarks based on joint degrees of freedom and can be used to estimate the position of hidden landmarks.⁹² Initial results indicate that this approach may be suitable for swimming applications,^{36,71} although the procedures are still time-consuming and complex, with 31 anatomical landmarks required during swimmer preparation for one arm and a portion of the trunk to be digitized, which perhaps offsets the time gained elsewhere.

Marker-Less Analysis

Another emerging approach found in other sports is a marker-less 3D analysis method based on the extraction of a swimmer's silhouette from video images.^{24,25} Marker-less systems have an advantage over other techniques for swimming applications, as form and drag caused by markers are central concerns.⁷³ The results of initial investigations suggest that this method shows similar reliability to manual digitisation approaches, but further investigation of system reliability has been suggested.⁴⁶ This method may help to reduce both participant preparation and processing time⁹³ and has also been investigated in other sports to provide real-time kinematic data on performance with promising results.⁹⁴ As with any new methodology, additional investigation will be required to fully assess the merits and feasibility of any new approach for applied settings. For instance, the system described by Ceseracciu, et al.²⁵ was tested for one arm only and for front-crawl swimming, and it remains to be seen if the same level of accuracy would be achieved for whole body kinematic analysis and for other swimming strokes. This trend towards automated procedures is likely to lead to increases in quantitative analysis practices as the time constraints associated with digitization are reduced. However, it could be reasonably argued that many of the automatic video analysis procedures are currently overtly costly to be applied in the majority of coaching settings, with one example costing over US \$35,000 to purchase the equipment and software (ProAnalyst, Xcitex Inc., Woburn, MA, USA). Additionally, with a concurrent growth in interest in alternative methods of quantifying swimming performance, some have argued that more suitable solutions are starting to emerge, such as the use of low cost Micro-Electro-Mechanical Systems (MEMS) inertial sensor devices.^{20,93,95} What is more likely is that integrated systems will become more prominent, with data measurements arising from multiple sources.

CONCLUSIONS AND RECOMMENDATIONS

The aim of this paper was to systematically review the process of applying video-based systems for the analysis of competitive swimming. It is clear that video can be used in a

variety of ways to provide feedback, and to aid technical development and to reduce the risk of injury. Video allows a coach to review, reflect and evaluate the development of many aspects of athletic preparation and can be used to facilitate both qualitative and quantitative analysis.

Video capture in swimming shares many common characteristics with other sports, but with additional considerations for underwater filming. The aquatic environment adds to the time, cost and complexity of implementing video analysis. In using video to provide feedback to swimmers, coaches must make appropriate decisions regarding the equipment, camera configurations and processing methods involved, and ensure they follow key recommendations.

There are a large number of factors to be considered when using video analysis for swimming applications and no common specifications or methodologies appear to exist. It could be argued that this lack of consistency is hindering the effectiveness of the technique. A more consistent approach would remove some of the confusion around the process and could facilitate increased use of video. Figure 9 provides a detailed flowchart of the various stages involved and is intended to provide recommendations that may aid decision making and perhaps improve the effectiveness of video for coaching purposes.

It would appear that the key feature of video is its adaptability to various applications. Video analysis can be tailored to suit the specific needs at the time. If rapid feedback is

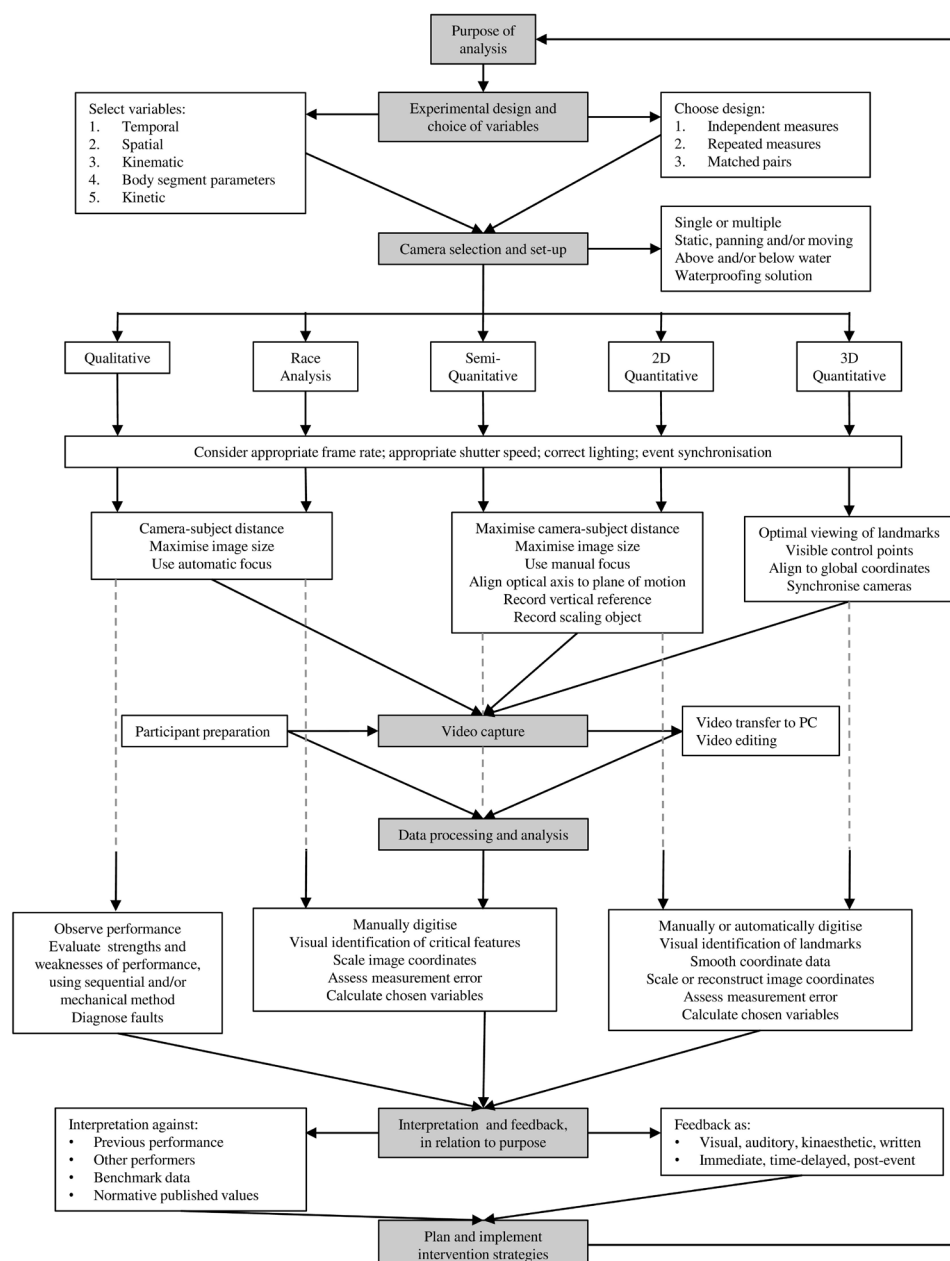

Figure 9: Flowchart detailing recommendations for the key steps to be followed and decisions to be made when undertaking video analysis in swimming.

required, video can facilitate instant review by both the coach and the swimmer. Additionally, video can be edited, processed and reviewed either qualitatively or quantitatively to provide an augmented feedback approach. Furthermore, video can be used to capture movement in both 2D and 3D for in-depth study or combined with other measurement tools. Finally, video can also be used in training, competition and research situations, and can capture movements both above and under the water. This versatility extends its application potential far beyond other analysis systems used in elite sport. With continued advances in video and software technology it is also likely that video will continue to remain an integral part of the elite training environment in future.

CONFLICTS OF INTEREST

The authors declare that they have no conflicts of interest.

ACKNOWLEDGEMENTS

This research is funded by the Irish Research Council Enterprise Partnership Scheme in conjunction with Swim Ireland (Grant award reference EPSPG\2012\361).

REFERENCES

1. Payton CJ. Motion analysis using video. In: Payton CJ, Bartlett R, eds. Biomechanical evaluation of movement in sport and exercise: The British Association of Sport and Exercise Sciences guidelines. Abingdon: Routledge; 2008b: 8-32.
2. Phillips E, Farrow D, Ball K, Helmer R. Harnessing and understanding feedback technology in applied settings. *Sports Medicine*. 2013; 3(10): 919-925. doi: [10.1007/s40279-013-0072-7](https://doi.org/10.1007/s40279-013-0072-7)
3. Wang JR, Parameswaran N. Survey of sports video analysis: research issues and applications. Paper presented at the Proceedings of the Pan-Sydney area workshop on visual information processing. 2004.
4. Wilson BD. Development in video technology for coaching. *Sports Technology*. 2008; 1(1): 34-40.
5. Barris S, Button C. A review of vision-based motion analysis in sport. *Sports Medicine*. 2008; 38(12): 1025-1043. doi: [10.2165/00007256-200838120-00006](https://doi.org/10.2165/00007256-200838120-00006)
6. Moeslund TB, Hilton A, Krüger V. A survey of advances in vision-based human motion capture and analysis. *Computer Vision and Image Understanding*. 2006; 104(2-3): 90-126.
7. Poppe R. Vision-based human motion analysis: an overview. *Computer Vision and Image Understanding*. 2007; 108(1-2): 4-18. doi: [10.1016/j.cviu.2006.10.016](https://doi.org/10.1016/j.cviu.2006.10.016)
8. Liebermann DG, Katz L, Hughes MD, Bartlett RM, McClements J, Franks IM. Advances in the application of information technology to sport performance. *Journal of Sports Sciences*. 2002; 20(10): 755-769.
9. D'Orazio T, Leo M. A review of vision-based systems for soccer video analysis. *Pattern Recognition*. 2010; 43(8): 2911-2926. doi: [10.1016/j.patcog.2010.03.009](https://doi.org/10.1016/j.patcog.2010.03.009)
10. Wang JR, Parameswaran N. Analyzing tennis tactics from broadcasting tennis video clips. Paper presented at the Proceedings of the 11th International Multimedia Modelling Conference. 2005.
11. Guadagnoli M, Holcomb W, Davis M. The efficacy of video feedback for learning the golf swing. *Journal of Sports Sciences*. 2002; 20(8): 615-622. doi: [10.1080/026404102320183176](https://doi.org/10.1080/026404102320183176)
12. Smith DJ, Norris SR, Hogg JM. Performance evaluation of swimmers: scientific tools. *Sports Medicine*. 2002; 32(9): 539-554.
13. Mooney R, Corley G, Godfrey A, et al. Analysis of swimming performance: perceptions and practices of US-based swimming coaches. *Journal of Sports Sciences*. 2015; 1-9. doi: [10.1080/02640414.2015.1085074](https://doi.org/10.1080/02640414.2015.1085074)
14. Vorontsov AR, Rumyantsev VA. Propulsive Forces in Swimming. In: Zatsiorsky VM, ed. Biomechanics in Sport: Performance, enhancement and injury prevention. Oxford: International Olympic Committee. Blackwell Science Ltd, 2008: 205-231.
15. Lees A. Technique analysis in sports: a critical review. *Journal of Sports Sciences*. 2002; 20(10): 813-828.
16. Counsilman JE. Forces in swimming two types of crawl stroke. *American Association for Health, Physical Education and Recreation*. 1955; 26(2): 127-139. doi: [10.1080/10671188.1955.10612813](https://doi.org/10.1080/10671188.1955.10612813)
17. Maglischo EW. Swimming fastest. Champaign, IL: Human Kinetics, 2003.
18. Schleihauf R. A hydrodynamic analysis of swimming propulsion. *Swimming III*, 1979: 70-109.
19. Toussaint HM, Truijens M. Biomechanical aspects of peak performance in human swimming. *Animal Biology*. 2005; 55(1): 17-40. doi: [10.1163/1570756053276907](https://doi.org/10.1163/1570756053276907)
20. Callaway AJ, Cobb JE, Jones I. A comparison of video and accelerometer based approaches to performance monitoring in swimming. *International Journal of Sports Science & Coaching*. 2009; 4(1): 139-153.

21. Figueiredo P, MacHado L, Vilas-Boas J, Fernandes R. Reconstruction error of calibration volume's coordinates for 3D swimming kinematics. *Journal of Human Kinetics*. 2011; 29(1): 35-40. doi: [10.2478/v10078-011-0037-6](https://doi.org/10.2478/v10078-011-0037-6)
22. Kwon YH, Casebolt JB. Effects of light refraction on the accuracy of camera calibration and reconstruction in underwater motion analysis. *Sports Biomechanics*. 2006; 5(2): 315-340.
23. Silvatti AP, Cerveri P, Telles T, Dias FAS, Baroni G, Barros RML. Quantitative underwater 3D motion analysis using submerged video cameras: accuracy analysis and trajectory reconstruction. *Computer Methods in Biomechanics and Biomedical Engineering*. 2013; 16(11): 1240-1248. doi: [10.1080/10255842.2012.664637](https://doi.org/10.1080/10255842.2012.664637)
24. Cohen J. Statistical power analysis for the behavioural sciences. 2nd ed. Lawrence Erlbaum Associates, 1988.
25. Ceseracciu E, Sawacha Z, Fantozzi S, et al. Markerless analysis of front crawl swimming. *Journal of Biomechanics*. 2011; 44(12): 2236-2242. doi: [10.1016/j.jbiomech.2011.06.003](https://doi.org/10.1016/j.jbiomech.2011.06.003)
26. Psycharakis SG, McCabe CB. Shoulder and hip roll differences between breathing and non-breathing conditions in front crawl swimming. *Journal of Biomechanics*. 2011; 44(9): 1752-1756. doi: [10.1016/j.jbiomech.2011.04.004](https://doi.org/10.1016/j.jbiomech.2011.04.004)
27. de Jesus K, Figueiredo PA, Gonçalves P, Vilas-Boas JP, Fernandes RJ. Effects of fatigue on kinematical parameters during submaximal and maximal 100-m butterfly bouts. *Journal of Applied Biomechanics*. 2012; 28(5): 599-607.
28. Figueiredo P, Seifert L, Vilas-Boas JP, Fernandes RJ. Individual profiles of spatio-temporal coordination in high intensity swimming. *Human Movement Science*. 2012; 31(5): 1200-1212. doi: [10.1016/j.humov.2012.01.006](https://doi.org/10.1016/j.humov.2012.01.006)
29. Komar J, Lepretre PM, Alberty M, et al. Effect of increasing energy cost on arm coordination in elite sprint swimmers. *Human Movement Science*. 2012; 31(3): 620-629. doi: [10.1016/j.humov.2011.07.011](https://doi.org/10.1016/j.humov.2011.07.011)
30. McCabe CB, Sanders RH. Kinematic differences between front crawl sprint and distance swimmers at a distance pace. *Journal of Sports Sciences*. 2012; 30(6): 601-608. doi: [10.1080/02640414.2012.660186](https://doi.org/10.1080/02640414.2012.660186)
31. Martens J, Daly D. Qualitative evaluation of water displacement in simulated analytical breaststroke movements. *Journal of Human Kinetics*. 2012; 32: 53-63. doi: [10.2478/v10078-012-0023-7](https://doi.org/10.2478/v10078-012-0023-7)
32. Puel F, Morlier J, Avalos M, Mesnard M, Cid M, Hellard P. 3D kinematic and dynamic analysis of the front crawl tumble turn in elite male swimmers. *Journal of Biomechanics*. 2012; 45(3): 510-515. doi: [10.1016/j.jbiomech.2011.11.043](https://doi.org/10.1016/j.jbiomech.2011.11.043)
33. Takeda T, Takagi H, Tsubakimoto S. Effect of inclination and position of new swimming starting block's back plate on track-start performance. *Sports Biomechanics*. 2012; 11(3): 370-381.
34. Thow JL, Naemi R, Sanders RH. Comparison of modes of feedback on glide performance in swimming. *Journal of Sports Sciences*. 2011; 30(1): 43-52. doi: [10.1080/02640414.2011.624537](https://doi.org/10.1080/02640414.2011.624537)
35. Bideault G, Herault R, Seifert L. Data modelling reveals inter-individual variability of front crawl swimming. *Journal of Science and Medicine in Sport*. 2013; 16(3): 281-285. doi: [10.1016/j.jsams.2012.08.001](https://doi.org/10.1016/j.jsams.2012.08.001)
36. Ceccon S, Ceseracciu E, Sawacha Z, et al. Motion analysis of front crawl swimming applying CAST technique by means of automatic tracking. *Journal of Sports Sciences*. 2013; 31(3): 276-287. doi: [10.1080/02640414.2012.729134](https://doi.org/10.1080/02640414.2012.729134)
37. de Jesus K, Figueiredo P, Gonçalves P, Pereira SM, Vilas-Boas JP, Fernandes RJ. Backstroke start kinematic and kinetic changes due to different feet positioning. *Journal of Sports Sciences*. 2013; 31(15): 1665-1675. doi: [10.1080/02640414.2013.794298](https://doi.org/10.1080/02640414.2013.794298)
38. Gourgoulis V, Boli A, Aggeloussis N, et al. The effect of leg kick on sprint front crawl swimming. *Journal of Sports Sciences*. 2013; 32(3): 278-289. doi: [10.1080/02640414.2013.823224](https://doi.org/10.1080/02640414.2013.823224)
39. Silva AF, Figueiredo P, Seifert L, Soares S, Vilas-Boas JP, Fernandes RJ. Backstroke technical characterization of 11-13 year-old swimmers. *Journal of Sports Science and Medicine*. 2013; 12(4): 623-629.
40. Strzala M, Krezalek P, Głab G, et al. Intra-cyclic phases of arm-leg movement and index of coordination in relation to sprint breaststroke swimming in young swimmers. *Journal of Sports Science and Medicine*. 2013; 12(4): 690-697.
41. Veiga S, Cala A, Frutos PG, Navarro E. Kinematical comparison of the 200 m backstroke turns between national and regional level swimmers. *Journal of Sports Science and Medicine*. 2013; 12(4): 730-737.
42. Atkison RR, Dickey JP, Dragunas A, Nolte V. Importance of sagittal kick symmetry for underwater dolphin kick performance. *Human Movement Science*. 2014; 33: 298-311. doi: [10.1016/j.humov.2013.08.013](https://doi.org/10.1016/j.humov.2013.08.013)
43. Cohen RCZ, Cleary PW, Harrison SM, Mason BR, Pease DL. Pitching effects of buoyancy during four competitive swimming strokes. *Journal of Applied Biomechanics*. 2014; 30(5): 609-618. doi: [10.1123/jab.2013-0260](https://doi.org/10.1123/jab.2013-0260)

44. do Couto JGM, Franken M, Castro FAS. Influence of different breathing patterns on front crawl kinematics. *Journal of Kinanthropometry and Human Performance*. 2014; 17(1): 82-90.
45. Gourgoulis V, Aggeloussis N, Mavridis, G, et al. Acute effect of front crawl sprint resisted swimming on the propulsive forces of the hand. *Journal of Applied Biomechanics*. 2013; 29(1): 98-104.
46. Monnet T, Samson M, Bernard A, David L, Lacouture P. Measurement of three-dimensional hand kinematics during swimming with a motion capture system: a feasibility study. *Sports Engineering*. 2014; 1-11.
47. Schnitzler C, Seifert L, Chollet D, Toussaint H. Effect of aerobic training on inter-arm coordination in highly trained swimmers. *Human Movement Science*. 2014; 33(1): 43-53. doi: [10.1016/j.humov.2013.12.004](https://doi.org/10.1016/j.humov.2013.12.004)
48. Takeda T, Itoi O, Takagi H, Tsubakimoto S. Kinematic analysis of the backstroke start: Differences between backstroke specialists and non-specialists. *Journal of Sports Sciences*. 2014; 32(7): 635-641.
49. Seifert L, Komar J, Crettenand F, Dadashi F, Aminian K, Millet GP. Inter-limb coordination and energy cost in swimming. *Journal of Science and Medicine in Sport*. 2014; 17(4): 439-444.
50. Veiga S, Cala A, Frutos PG, Navarro E. Comparison of starts and turns of national and regional level swimmers by individualized-distance measurements. *Sports Biomechanics*. 2014; 13(3): 285-295. doi: [10.1080/14763141.2014.910265](https://doi.org/10.1080/14763141.2014.910265)
51. Zatoń K, Szczepan S. The impact of immediate verbal feedback on the improvement of swimming technique. *Journal of Human Kinetics*. 2014; 41: 143-154. doi: [10.2478/hukin-2014-0042](https://doi.org/10.2478/hukin-2014-0042)
52. Gatta G, Cortesi M, Lucertini F, Benelli P, Sisti D, Fantozzi S. Path linearity of elite swimmers in a 400 m front crawl competition. *Journal of Sports Science and Medicine*. 2015; 14(1): 69-74.
53. Osborough C, Daly D, Payton C. Effect of swim speed on leg-to-arm coordination in unilateral arm amputee front crawl swimmers. *Journal of Sports Sciences*. 2015; 33(14): 1523-1531.
54. Thomas JR, Nelson JK. Research methods in physical activity. 4th ed. Champaign, IL: Human Kinetics, 2001.
55. Gourgoulis V, Aggeloussis N, Vezos N, Kasimatis P, Antoniou P, Mavromatis G. Estimation of hand forces and propelling efficiency during front crawl swimming with hand paddles. *Journal of Biomechanics*. 2008; 41(1): 208-215.
56. Kwon YH, Kwak CS. Development of an inverse-perspective for underwater motion analysis in swimming. *Sport Science*. 1996; 7: 1-7.
57. Payton CJ, Baltzopoulos V, Bartlett RM. Contributions of rotations of the trunk and upper extremity to hand velocity during front crawl swimming. *Journal of Applied Biomechanics*. 2002; 18(3): 243-256.
58. Yanai T, Hay JG, Gerot JT. Three-dimensional videography of swimming with panning periscopes. *Journal of Biomechanics*. 1996; 29(5): 673-678.
59. Tor E, Ball K, Pease, D, Hopkins W. A comparison between single and multi-camera swimming race analysis systems. Paper presented at the International Society of Biomechanics in Sport, Melbourne, Australia. 2012.
60. Mooney R. A biomechanical analysis of the swimming track start: A comparison of two starting block designs. Paper presented at the Proceedings of the British Association of Sport & Exercise Sciences Annual Conference, UK: University of Essex. 2011.
61. Sanders, RH, Psycharakis S, McCabe CB, et al. Analysis of swimming technique: State of the art applications and implications. *Portuguese Journal of Sport Sciences*. 2006; 6(2): 20-24.
62. Chollet D, Chalies JC, Chatard JC. A new index of coordination for the crawl: description and usefulness. *International Journal of Sports Medicine*. 2000; 20: 54-59.
63. Nikodelis T, Kollias I, Hatzitaki V. Bilateral inter-arm coordination in freestyle swimming: Effect of skill level and swimming speed. *Journal of Sports Science*. 2005; 23(7): 737-745.
64. Cappaert JM, Pease, DL, Troup J. Three-dimensional analysis of the men's 100-m freestyle during the 1992 Olympic games. *Journal of Applied Biomechanics*. 1995; 11: 103-112.
65. Lauder MA, Dabnichki P, Bartlett RM. Improved accuracy and reliability of sweepback angle, pitch angle and hand velocity calculations in swimming. *Journal of Biomechanics*. 2001; 34(1): 31-39. doi: [10.1007/s12283-011-0070-7](https://doi.org/10.1007/s12283-011-0070-7)
66. Atkinson G, Nevill A. Statistical methods for assessing measurement error (reliability) in variables relevant to sports medicine. *Sports Medicine*. 1988; 26: 217-238.
67. Bland JM, Altman DG. Statistical methods for assessing agreement between two methods of clinical measurement. *The Lancet*. 1986; 327(8476): 307-310.
68. Hughes M, Cooper S, Nevill A. Analysis procedures for non-parametric data from performance analysis. *International Jour-*

nal of Performance Analysis in Sport. 2002; 2: 6-20.

69. Payton CJ, Bartlett RM. Estimating propulsive forces in swimming from three-dimensional kinematic data. *Journal of Sports Sciences*. 1995; 13(6): 447-454.

70. Le Sage T, Bindel A, Conway PP, Justham, LM, Slawson SE, West AA. Embedded programming and real time signal processing of swimming strokes. *Sports Engineering*. 2011; 14: 1-14. doi: [10.1007/s12283-011-0070-7](https://doi.org/10.1007/s12283-011-0070-7)

71. Magalhaes FA, Sawacha Z, Di Michele R, Cortesi M, Gatta G, Fantozzi S. Effectiveness of an automatic tracking software in underwater motion analysis. *Journal of Sports Science & Medicine*. 2013; 12(4): 660-667.

72. Psycharakis SG, Sanders RH. Shoulder and hip roll changes during 200-m front crawl swimming. *Medicine and Science in Sports and Exercise*. 2008; 40(12): 2129-2136.

73. Kjendlie PL, Olstad BH. Automatic 3D motion capture of swimming: marker resistance. *Medicine & Science in Sports & Exercise*. 2012; 44(5): S320.

74. Knudson D. Qualitative biomechanical principles for application in coaching. *Sports Biomechanics*. 2007; 6(1): 109-118.

75. Briki W, Den Hartigh RJR, Hauw D, Gernigon C. A qualitative exploration of the psychological contents and dynamics of momentum in sport. *International Journal of Sport Psychology*. 2012; 43(5): 365-384.

76. Clark SE, Ste-Marie DM. The impact of self-as-a-model interventions on children's self-regulation of learning and swimming performance. *Journal of Sports Sciences*. 2007; 25(5): 577-586.

77. Dowrick PW. A review of self modeling and related interventions. *Applied and Preventive Psychology*. 1999; 8(1): 23-39. doi: [10.1016/S0962-1849\(99\)80009-2](https://doi.org/10.1016/S0962-1849(99)80009-2)

78. Ste-Marie DM, Rymal A, Vertes K, Martini R. Self-Modeling and competitive beam performance enhancement examined within a self-regulation perspective. *Journal of Applied Sport Psychology*. 2011; 23(3): 292-307. doi: [10.1080/10413200.2011.558049](https://doi.org/10.1080/10413200.2011.558049)

79. Weinberg RS, Gould D. Foundations of sport and exercise psychology. Champaign, IL: Human Kinetics, 2011.

80. Mason BR. Biomechanical services and research for top level swimming: the Australian Institute of Sport model. Paper presented at the Biomechanics and Medicine in Swimming XI, Oslo, Norway. 2010.

81. Payton CJ. Biomechanics support for British world class dis-

ability swimming. *SportEx Medicine*. 2008a; 36(4): 9-13.

82. Rucci JA, Tomporowski PD. Three types of kinematic feedback and the execution of the hang power clean. *The Journal of Strength & Conditioning Research*. 2010; 24(3): 771-778. doi: [10.1519/JSC.0b013e3181cbab96](https://doi.org/10.1519/JSC.0b013e3181cbab96)

83. Becker T, Havriluk R. Quantitative data supplements qualitative evaluation of butterfly swimming. Paper presented at the Biomechanics and medicine in swimming XI, Oslo. 2010.

84. BardenJM, Kell RT, Kobsar D. The effect of critical speed and exercise intensity on stroke phase duration and bilateral asymmetry in 200-m front crawl swimming. *Journal of Sports Sciences*. 2011; 29(5): 517-526. doi: [10.1080/02640414.2010.543912](https://doi.org/10.1080/02640414.2010.543912)

85. Seifert L, Leblanc H, Chollet D, Delignieres D. Inter-limb coordination in swimming: effect of speed and skill level. *Human Movement Science*. 2010; 29(1): 103-113.

86. Evershed J, Burkett B, Mellifont R. Musculoskeletal screening to detect asymmetry in swimming. *Physical Therapy in Sport*. 2013. doi: [10.1016/j.pts.2013.02.002](https://doi.org/10.1016/j.pts.2013.02.002)

87. Seifert L, Chollet D. Modelling spatial-temporal and coordinative parameters in swimming. *Journal of Science and Medicine in Sport*. 2009; 12(4): 495-499. doi: [10.1016/j.jsams.2008.03.002](https://doi.org/10.1016/j.jsams.2008.03.002)

88. Lyttle A, Mason B. A kinematic and kinetic analysis of the freestyle and butterfly turns. *Journal of Swimming Research*. 1997; 12: 7-11.

89. Fulton SK, Pyne DB, Burkett BJ. Validity and reliability of kick count and rate in freestyle using inertial sensor technology. *Journal of Sports Sciences*. 2009; 27(10): 1051-1058. doi: [10.1080/02640410902998247](https://doi.org/10.1080/02640410902998247)

90. Barris S, Button C. A review of vision-based motion analysis in sport. *Sports Medicine*. 2008; 38(12): 1025-1043. doi: [10.2165/00007256-200838120-00006](https://doi.org/10.2165/00007256-200838120-00006)

91. Slawson SE, Conway PP, Justham LM, West AA. The development of an inexpensive passive marker system for the analysis of starts and turns in swimming. *Procedia Engineering*. 2010; 2(2): 2727-2733. doi: [10.1016/j.proeng.2010.04.058](https://doi.org/10.1016/j.proeng.2010.04.058)

92. Cappelzo A, Catani F, Della Croce U, Leardini A. Position and orientation in space of bones during movement: anatomical frame definition and determination. *Clinical Biomechanics*. 1995; 10(4): 171-178.

93. Dadashi F, Millet GP, Aminian K. Inertial measurement unit and biomechanical analysis of swimming: an update. *Swiss Society of Sports Medicine*. 2013; 61: 21-26.

94. El-Sallam A, Bennamoun M, Sohel F, Alderson J, Lyttle A, Rossi M. A low cost 3D markerless system for the reconstruction of athletic techniques. Paper presented at the 2013 IEEE Workshop on Applications of Computer Vision (WACV). 2013.

95. Davey N, Anderson M, James DA. Validation trial of an accelerometer-based sensor platform for swimming. *Sports Technology*. 2008; 1(4-5): 202-207.